

## Data sheet

### BACnet® IP inputs (In-A, In-B)

MULTICAL® 403

MULTICAL® 603

MULTICAL® 803

- BTL certified and listed
- Compatible with ANSI/ASHRAE-135, ISO 16484-5
- Communication via UDP over IPv4
- Support for PQT Controller
- IP assignment via DHCP or static IP
- Ethernet 10/100 base t
- Reading of meter data
- High data rate



## Contents

---

Introduction	2
Cable connections	3
Communication from module	4
Technical data	5
Ordering	6
Configuration	6
Displayed information	7

## Introduction

---

A high-performance BACnet® IP module has been developed for the MULTICAL® energy meters. BACnet® IP enables MULTICAL® to be integrated into building automation systems and to be part of industrial applications.

The module is BTL-certified and -listed to ensure compatibility with the BACnet® standard. BACnet® IP communicates via Ethernet and exchanges data at 10 or 100 Mbits/s.

### Application

The BACnet® IP module is designed with focus on high flexibility reading a large amount of data from MULTICAL® to be used as input for monitoring, control and data analysis purposes.

BACnet® IP presents data in a standardized format and supports fast exchange of meter data like flow, energy and temperatures.

### Analysis

MULTICAL® thermal energy meters support high quantities of data, and all data relevant for analysis can be read.

### Alarms

The MULTICAL® info codes for general alarms, flow errors, temperature errors, water leakage, very high flow, air in the system and incorrect flow direction are available to the BACnet® system.

### Control and regulation

Data can be read out at intervals of few seconds at high speed whereby the data can be used for control and regulation purposes.

### Remote control of PQT Controller

Remote control of PQT Controller is possible as the limit settings of PQT Controller can be read and written via BACnet® IP commands. Thus, the flow can be controlled by the building control system simply by setting one or more of the limit settings in PQT Controller.

### Installation

The module is easily mounted in a free module space on the meter.

A configuration may be needed if a certain setup of IP-addressing is needed.

⚡ The module is power-supplied from the meter's internal 230 VAC or 24 VAC High-Power supply.

## Cable connections

### Terminals

Max cable size: 1.5 mm<sup>2</sup>

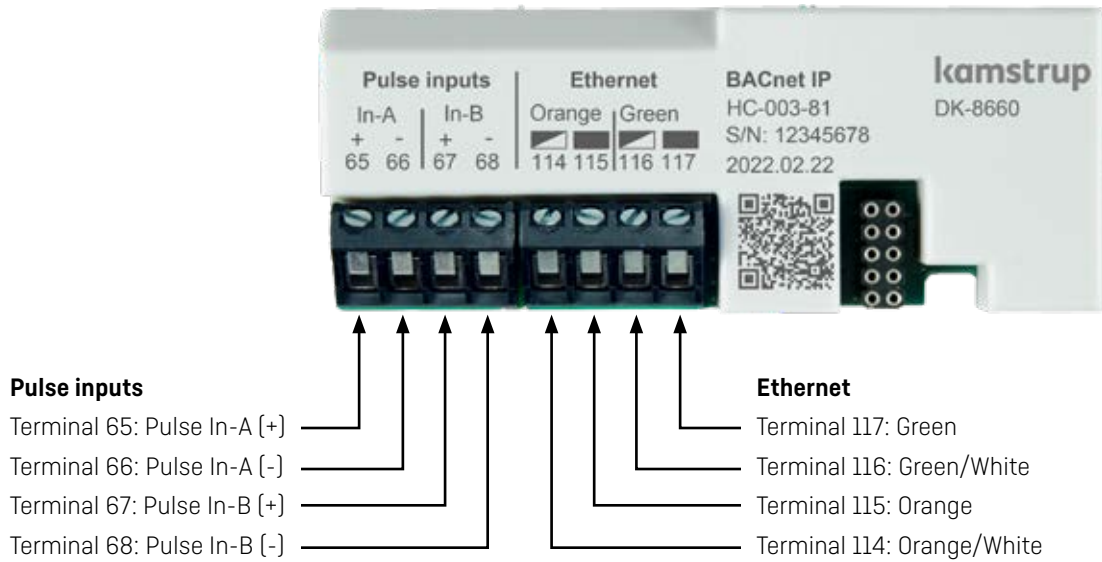

### Pulse inputs

The module is equipped with two pulse inputs, In-A and In-B, to collect and accumulate pulses, e.g. from water and electricity meters.

The pulse inputs are physically placed on the module. However, the accumulation and logging of values are performed by the MULTICAL® calculator.

When installing a module with pulse inputs in slot 2 of MULTICAL® 603 and MULTICAL® 803, the pulse inputs are registered in the meter as In-A2 and In-B2.

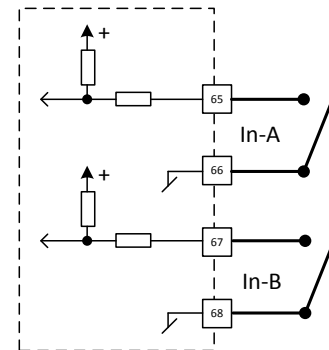

### Ethernet

☞ Use a standard patch cable cut in half. Then you can feed the cable end without RJ45 plug through the holes in the meter and connect the wires to the module. The RJ45 connector then goes into an Ethernet switch.

The colour coding on the module is according to the TIA/EIA-568, T568B termination.

The colours on various cable brands may deviate.

## Communication from module

---

### Protocol

BACnet® is BTL-certified according to ASHRAE 135 and ISO 16484-5.

### BACnet® IP

The module for MULTICAL® heat/cooling meters communicates BACnet® IP via IPV4. The module is supported by MULTICAL® 403, MULTICAL® 603 and MULTICAL® 803. BACnet® IP enables a large amount of MULTICAL® data to be accessible via the BACnet® network. Data is transferred at high speed and high reliability. BACnet® IP is suitable for applications both for monitoring and regulation as well as alarm purposes.

### PQT Controller

The BACnet® IP module is prepared to support control of PQT Controller. This is only possible in MULTICAL® 603 and MULTICAL® 803, having room for 2 or 4 communication modules. PQT Controller is a module that can regulate flow based on limit settings in the module against the actually measured flow and/or the actual temperatures. PQT Controller is connected to a motorized valve, and its built-in regulator controls whether the valve opens, closes or keeps its position.

Using PQT Controller in combination with the BACnet® IP module, you can control the flow remotely via your BACnet® application.

### Datagram

The module enables access to a wide range of meter registers. A large number of the registers are presented as analog input registers, other registers are available as positive integer values. Most registers are read-only. The registers used to change the set points of PQT Controller can of course be changed.

The table below is only a subset of the available information.

Description	ID	Name	Most often used units	Read/Write
Device	Last 5 digits of meter number	Kamstrup HC-003-81	Dimensionless	Read
Analog Input	AI-0	Flow 1	l/h, m <sup>3</sup> /h	Read
Analog Input	AI-1	Flow 2	l/h, m <sup>3</sup> /h, No Units	Read
Analog Input	AI-2	Actual power	W, kW, MW, j, kj, Gj, [No Units]	Read
Analog Input	AI-3	Actual Power E14/E16	W, kW, MW, j, kj, Gj, [No Units]	Read
Analog Input	AI-4	Temp. 1 Inlet	degrees Celcius	Read
Analog Input	AI-5	Temp. 2 Outlet	degrees Celcius	Read
Analog Input	AI-6	Temp. 3	degrees Celcius, No Units	Read
Analog Input	AI-7	Temp. 4	degrees Celcius, No Units	Read
Analog Input	AI-8	Differential temp.	degrees Kelvin	Read
Analog Input	AI-9	Pressure 1	Bar, No Units	Read
Analog Input	AI-10	Pressure 2	Bar, No Units	Read
Positive Integer Value	PIV-13	PQT Flow set point	l/h	Read/Write
Positive Integer Value	PIV-14	PQT Power set point [x*10 <sup>-1</sup> ]	kW	Read/Write
Positive Integer Value	PIV-15	PQT Delta t set point [x*10 <sup>-2</sup> ]	degrees Kelvin	Read/Write
Positive Integer Value	PIV-16	PQT t2 set point [x*10 <sup>-2</sup> ]	degrees Celcius	Read/Write

For a complete overview of available data objects, see the PICS: [55123244 on kamstrup.com](https://www.kamstrup.com/55123244).

## Technical data

---

### Physical

For installation in MULTICAL® 403, MULTICAL® 603 and MULTICAL® 803

### Mechanical data

Dimensions (L x W x D) 90 x 35 x 14 mm

Weight < 45 g

### MULTICAL® supply

High-Power SMPS

### Communication

Protocol BACnet® IP

Data rate 10/100 Mbit/s

### Data refresh rate

Data from the meter to the module is refreshed each time the meter completes an integration. The integration mode is defined by the meter's L-code.

### Bus-specific

Type Ethernet IPV4

Galvanic isolation > 2 kV

### Pulse inputs

Input type Contact input

Open voltage 3.6 V

Current ≤ 5 µA

Max cable length 10 m

### Environment

Operational temperature 5 °C – 55 °C

Humidity 25 – 85 % RH non-condensing

### Markings/approvals

CE, MID together with the type approval of MULTICAL® 603 and MULTICAL® 803

### Additional documentation

BTL certification BACnet® Application Specific Controller Profile (B-ASC)

5512-3244 BACnet® Protocol Implementation Conformance Statement, PICS

### Programming

Configuration/Firmware Via the optical read-out head or the multipole connector on the module using METERTOOL HCW

## Ordering

---

Description	Order No.
BACnet® IP, inputs (In-A, In-B)	HC-003-81
USB configuration cable for H/C-modules	6699-035
Infrared optical read-out head w/USB A plug	6699-099
METER TOOL HCW	<a href="http://www.kamstrup.com">www.kamstrup.com</a>

## Configuration

---

Product type of module	XX	YY	ZZZ
BACnet® IP, inputs (In-A, In-B)	81	01	100
<b>System</b>			
BACnet® IP		01	
<b>Datagram</b>			
Default datagram			100
Reserved			ZZZ

## Further configurations

Object name	An optional text describing the actual device, e.g. "Meter flat 3"
Object Identifier	An optional number to further identify the actual device
Host name	Used to name the device so its IP address can be found
IP assignment	Selection of static or dynamic address (DHCP) IP assignment
IP address	The IP address assigned to the BACnet® module
Subnet	Subnet mask, typical value is 255.255.255.0
Gateway	The IP address assigned to the router
BACnet® UDP port	The UDP port used to access the module
UTC offset	Offset between local time and UTC time
BACnet® IP mode	Select among: – Normal – Foreign Device via IP – Foreign Device via Hostname
Foreign Device BBMD IP Address	IP address assigned to the BBMD
Foreign Device BBMD Hostname	Hostname assigned to the BBMD
Foreign Device BBMD UDP Port	The UDP port used to access the BBMD
Foreign Device Subscription Lifetime	How long time (in seconds) the module subscribes to the BBMD data connection

**BBMD:** BACnet® Broadcast Management Device. This device enables BACnet® data traffic between BACnet® IP devices in various subnets.

## Displayed information

Module information can be read by selecting "TECH loop" on the MULTICAL® display.

- Module in module slot 1: Select menu 2-101 in "TECH loop".
- Module in module slot 2: Select menu 2-201 in "TECH loop".
- Module in module slot 3: Select menu 2-301 in "TECH loop".
- Module in module slot 4: Select menu 2-401 in "TECH loop".

Menu	Menu index	Information	Display example
2-x01	31	Module type and configuration	
2-x01-1	32	Module firmware and revision	
2-x01-2	33	Module serial number	
2-x01-5	47	Link information *	
2-x01-6	49	Module status **	

\* Link information has 4 bits of information:

Bit number	Value when bit = 1	Meaning	Value when bit = 0	Meaning
3	8	100 Mbit	0	10 Mbit
2	4	Full duplex	0	Half duplex
1	2	Autonegotiation complete	0	Autonegotiation in progress
0	1	Link	0	No link

A value of 15 means: 100 Mbit, Full duplex, Autonegotiation complete and Link

\*\* Module status has 3 bits of information :

Bit number	Value when bit = 1	Meaning	Value when bit = 0	Meaning
2	4	No connection	0	Link
1	2	Internal error	0	OK
0	1	No configuration	0	OK

If the module status shows other values than 0 or 4, the module must be sent in for repair.

BACnet® IP, inputs (In-A, In-B)

MULTICAL® 403

MULTICAL® 603

MULTICAL® 803

---

**Kamstrup A/S**

Industrivej 28, Stilling  
DK-8660 Skanderborg

T: +45 89 93 10 00

F: +45 89 93 10 01

[info@kamstrup.com](mailto:info@kamstrup.com)

[kamstrup.com](http://kamstrup.com)