

Data sheet

BACnet® MS/TP inputs (In-A, In-B)

MULTICAL® 403

MULTICAL® 603

MULTICAL® 803

- BTL certified and listed
- Compatible with ANSI/ASHRAE-135, ISO 16484-5
- Supports BACnet® COV notifications
- RS-485 galvanic isolated from



BACnet® is a registered trademark of American Society of Heating, Refrigerating and Air-Conditioning Engineers [ASHRAE].

Contents

| | |
|---------------------------|---|
| Installation | 2 |
| Cable connections | 3 |
| Communication from module | 4 |
| BACnet® data | 5 |
| Technical data | 6 |
| Ordering | 7 |
| Configuration | 7 |
| Displayed information | 8 |

Introduction

A high-performance BACnet® module has been introduced with MULTICAL® 403, MULTICAL® 603 and MULTICAL® 803 energy meters. BACnet® the MS/TP communication module allows MULTICAL® meters to be integrated into a building automation system or to be part of industrial installations.

The module is BTL certified and listed, which guarantees compatibility with BACnet® standard.

Application

The BACnet® module is designed with a high flexibility focus to meet a wide range of applications. The BACnet® module supports rapid exchange of meter data, e.g. flow, energy and temperatures to facilitate monitoring and control tasks.

Analysis

MULTICAL® energy meters support high quantities of data, and all data relevant for analysis can be read out.

Alarms

The MULTICAL® info codes for general alarms, flow errors, temperature errors, water leakage, very high flow, air in the system and incorrect flow direction are available to the BACnet® system.

Control and regulation

The module supports Change Of Values (COV). This is part of BACnet® event notification. BACnet® clients, such as PLC's, can subscribe to changes to values in the MULTICAL® variables. This feature results in quick response times, which are necessary for alarms and control purposes.

Installation

The module is easily mounted on a free module space in the meter. A configuration may be required if a specific BACnet® MAC address is required.

Configuration of BACnet® MAC address, Object name and Object identifier, can be performed with METERTOOL HCW through the MULTICAL® optical eye or through the 10-pole connector on the module.

↻ The module is supplied via the meter's internal 230 VAC or 24 VAC power supply.

Cable connections

Terminals

Max cable size 1.5 mm²

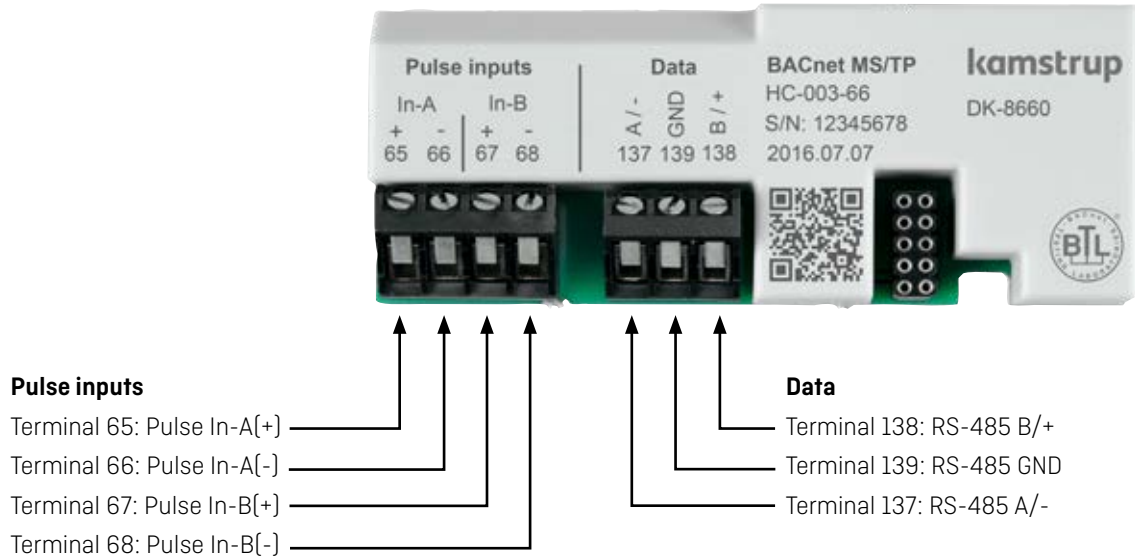

Pulse inputs

The module is equipped with two pulse inputs, In-A and In-B, to collect and accumulate pulses, e.g. from water and electricity meters.

The pulse inputs are physically placed on the module. However, the accumulation and logging of values are performed by the MULTICAL® calculator.

When installing a module with pulse inputs in slot 2 of MULTICAL® 603 and MULTICAL® 803, the pulse inputs will be registered in the meter as In-A2 and In-B2.

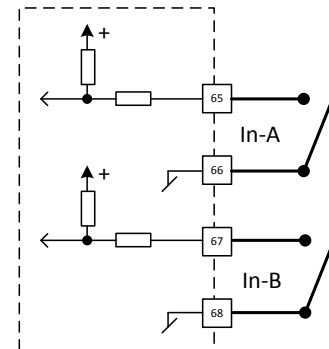

Data

The communication is RS-485 based. To ensure proper communication a twisted shielded pair cable is mandatory. The shield must be connected to the GND Terminal.

All devices in the RS-485 system are preferably connected in a line-topology. Communication line to be terminated with 120 Ohm resistors between the A and B wires, in both ends.

Communication from module

Protocol

BACnet® BTL certified according with ASHRAE 135 and ISO 16484-5.

BACnet® MS/TP Addressing

The module can be addressed as master in the MAC address range 1-127 and as a slave when configured in the MAC address range 128-254.

When ordering the modules together with a MULTICAL® the BACnet® MAC address is determined by the last two or three digits of the customer number similar the BACnet® Object identifier is also set to the meter's costumer number.

Note: When the MAC address is in the slave address range, 128 – 254, the BACnet® master will only know the presence of those slave-modules that are setup explicit in the master.

Note: The BACnet® MAC address is configured and stored in the MULTICAL® and referred to as "BUS address" in the METERTOOL HCW.

Module Identification

BACnet® also have an **Object name** and an **Object identifier** for further description of the BACnet device.

The Object name is just a text describing the module in more detail. The default is name is "Kamstrup HC-003-66" followed by the customer number.

The Object identifier is an additional number used to define the meter. The default identifier is the Customer number but can be set to any meaningful value.

Communication speed

The module support automatic baud rate detection in the range from 9600 to 115200 baud.

Supported BACnet® Services

The BACnet® module supports the following services:

- BACnet® Application Specific Controller (B-ASC)
- BACnet® Master Mode using address range 1-127
- BACnet® Slave Mode using address range 128-254

BACnet® data

The BACnet module can be used in any of the MULTICAL® XX3 meters.

However, some registers found in MULTICAL® 803 does not exist in MULTICAL® 403 and 603, and some registers found in MULTICAL® 603 does not exist in MULTICAL® 403.

If a meter does not have a requested register, the module will set the BACnet Reliability property of that register to "No Sensor".

Following registers are included in the BACnet Object Map:

| Analog Input | Analog Input | Positive Integer Values |
|--------------------------------|---------------------------|------------------------------|
| Flow V1 actual | Energy E14 | Info code |
| Flow V2 actual | Energy E15 | Operating hours |
| Actual Power | Energy E16 | Error hour counter |
| Actual Power 2 (E14/E16) | Tariff TA2 | Config No. 1 |
| t1 actual | Tariff TA3 | Config No. 2 |
| t2 actual | Tariff TA4 | Config No. 3 |
| t3 actual | Heat energy A1 | Config No. 4 |
| t4 actual | Heat energy A2 | Customer No. 2 |
| t1-t2 diff. temp. | Volume V1 | Customer No. 1 |
| P1 actual | High resolution volume V1 | Serial No. |
| P2 actual | Volume V2 | Meter type |
| Heat energy E1 | Pulse input A1 | Meter Main/Sub type |
| High resolution heat energy E1 | Pulse input B1 | Fluid Type and Concentration |
| Heat energy E2 | Pulse input A2 | |
| Cooling energy E3 | Pulse input B2 | |
| High resolution heat energy E3 | COP | |
| Inlet energy E4 | t5 limit | |
| Outlet energy E5 | Power Input B1 | |
| Tap water energy E6 | QP average time | |
| Tap water energy E7 | Tariff limit TL2 | |
| Energy E8 | Tariff limit TL3 | |
| Energy E9 | Tariff limit TL4 | |
| Energy E10 | Mass M1 | |
| Energy E11 | Mass M2 | |
| Energy E12 | Mass M3 | |
| Energy E13 | Mass M4 | |

For detailed description of the data object see the PICS [5512-2063](#)

Technical data

Physical

For installation in MULTICAL® 403, MULTICAL® 603 and MULTICAL® 803.

Mechanical data

Dimensions [L x W x D] 90 x 35 x 14 mm

Weight < 45g.

MULTICAL® Supply

↻ AC supply

Communication

Protocol BACnet® MS/TP, ASHRAE 135.1-2016, ISO 16484-5

Baud rates [Auto] 9600 bit/s

19200 bits/s

38400 bits/s

57600 bits/s

76800 bits/s

115200 bits/s

BACnet® vendor ID 546 [Kamstrup]

Object name Kamstrup HC-003-66

Object Identifier 5 last digits of the serial number

Address range 1...254

Data refresh rate

Data from the meter to the module are refreshed each time the meter completes an integration. Integration mode is defined by the meter's L-code.

Bus specific

Type RS-485, 2 wires + GND

Galvanic isolation > 2kV

Pulse inputs

Input type Contact input

Open voltage 3,6 V

Current ≤ 5 µA

Max cable length 10 m

Environment

Operational temperature 5 °C – 55 °C

Humidity 25 – 85 % RH non-condensing

Markings/approvals

CE, MID together with the type approval of MULTICAL® 403, MULTICAL® 603 and MULTICAL® 803.

Compatibility

ASHRAE 135/ ISO 16484-5 BACnet standard

Additional documentation

BTL certification

[5512-2063](#)

[5512-2588](#)

BACnet® Application Specific Controller Profile (B-ASC)

BACnet® Protocol Implementation Conformance Statement, PICS

RS 485 Guide to Successful Communication

Programming

Configuration/firmware Via the optical readout head or the multipole connector on the module using METERTOOL HCW

Ordering

Description

BACnet MS/TP, inputs (In-A, In-B)
 USB configuration cable for H/C-modules
 Infrared optical readout head w/USB A plug
 METERTOOL HCW

Order No.

HC-003-66
 6699-035
 6699-099
www.kamstrup.com

Configuration

| | XX | YY | ZZZ |
|-----------------------------------|----|----|-----|
| Product type of module | | | |
| BACnet MS/TP, inputs (In-A, In-B) | 66 | 00 | 100 |
| Communication settings | | | |
| Auto | | 00 | |
| Datagram | | | |
| Default datagram | | | 100 |
| Reserved | | | ZZZ |

Displayed information

Module information can be read by selecting "TECH loop" on the MULTICAL® display.

Module in module slot 1: select menu 2-101 in "TECH loop"

Module in module slot 2: select menu 2-201 in "TECH loop"

Module in module slot 3: select menu 2-301 in "TECH loop"

Module in module slot 4: select menu 2-401 in "TECH loop"

| Menu | Menu index | Information | Display example |
|---------|------------|-------------------------------|-----------------|
| 2-x01 | 31 | Module type and configuration | |
| 2-x01-1 | 32 | Module firmware and revision | |
| 2-x01-2 | 33 | Module serial number | |
| 2-x01-4 | 34 | Bus Address | |

Kamstrup A/S

Industrivej 28, Stilling
 DK-8660 Skanderborg
 T: +45 89 93 10 00
 F: +45 89 93 10 01
 info@kamstrup.com
 kamstrup.com